

OPERATOR'S MANUAL

42" & 46" SNOW PLOW & DOZER BLADE

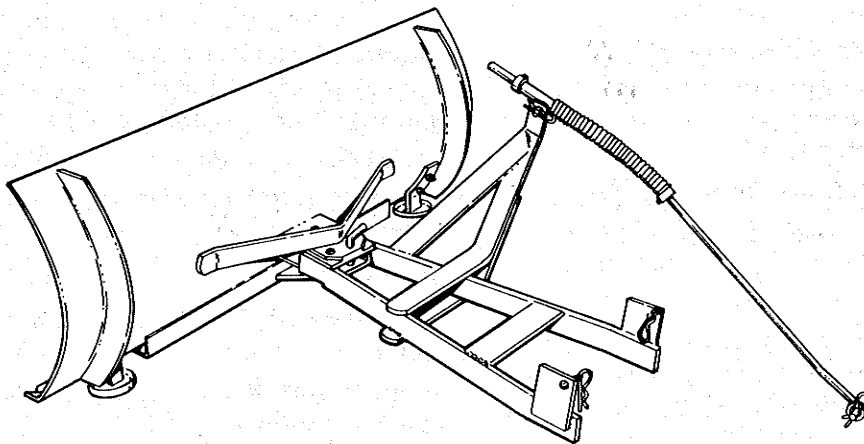

42" SNOW PLOW & DOZER BLADE

MFG. NO. 1690085

HITCH ASSEMBLY

MFG. NO. 1690497

46" SNOW PLOW & DOZER BLADE

MFG. NO. 1690088

HITCH ASSEMBLY

MFG. NO. 1690498

Contents

SAFETY RULES	1
ASSEMBLY, INSTALLATION, & REMOVAL	2
OPERATION & NORMAL CARE	5
ADJUSTMENTS	6

Accessories

There are many optional accessories and attachments available for your tractor to make plowing and dozing easier. See your dealer if you wish to purchase any of the following:

WHEEL WEIGHTS, REAR — improve traction in loose soil or on slippery surfaces. Use two rear wheel weights (one per wheel) when operating on slopes greater than 20 percent (11.3°).

WHEEL WEIGHTS, FRONT — improve steering.

ELECTRIC LIFT KIT — raises and lowers snow plow/dozer blade and other attachments with the flip of a switch.

DUAL LIFT LEVER — provides separate lift control of front and rear-mounted attachments. Especially useful when using dozer blade and rotary tiller at the same time.

WINTERIZING KIT — (14 & 16 HP Briggs & Stratton engine only.) Includes shield to keep carburetor warm and side-vented gas cap.

CHAINS — provide additional traction.

COUNTERWEIGHT SPRING KIT — makes it easier to lift snow plow/dozer blade.

SNOW CAB — protects operator from weather.

HOURMETER — records engine operating time in tenths of an hour.

REAR LIGHT KIT — lights path when traveling in reverse at night.

Safety Rules



Read these safety rules and follow them closely. Failure to obey these rules could result in loss of control of vehicle, severe personal injury to yourself or bystanders, or damage to property or equipment. The triangle  in the text signifies important cautions or warnings which must be followed.

 ALL WARNING, CAUTION, and instructional messages on this attachment and on your tractor should be carefully read and obeyed. Personal bodily injury can result when these instructions are not followed.

GENERAL

- Read the operator's manual carefully. Be thoroughly familiar with the controls and proper use of the equipment. Know how to stop the unit and disengage the controls quickly.
- Never allow children to operate the machine. Do not allow adults to operate it without proper instruction.
- Keep the area of operation clear of all persons, particularly small children, and pets.
- Do not carry passengers.
- Make sure:
 - a. tractor and attachments are in good operating condition,
 - b. all safety devices and shields are in place
 - c. and in good working condition, and
 - d. all adjustments (skid shoe height, etc.) have been made.

PREPARATION

- Handle gasoline with care — it is highly flammable.
 - a. Use approved gasoline container.
 - b. Never remove the cap of the fuel tank or add gasoline to a running or hot engine, or fill the fuel tank indoors. Wipe up spilled gasoline.

- Do not run the engine indoors. Exhaust fumes are dangerous.
- Shift into neutral before attempting to start the engine.
- Wear heavy footwear. Do not operate tractor when barefoot or when wearing open sandals or canvas shoes.

OPERATION

- Do not allow anyone to use the snow plow/dozer blade unless they have been instructed on how to operate it safely.
- Never attempt to adjust, repair or service the snow plow/dozer blade while the tractor engine is running.
- Do not allow others near the snow plow/dozer blade while it is being used.
- Use the snow plow/dozer blade only in daylight, or good artificial light.
- Always lower the snow plow/dozer blade completely to the ground when leaving it unattended to prevent it from being accidentally lowered and causing injury.
- Always operate the tractor at reasonable speeds to prevent the blade from catching an object and stopping the tractor abruptly.

4. Hook the spring (C) into the push bar as shown. Stretch the spring with a pliers to hook spring on eyebolt (A).
5. Repeat steps 3 and 4 for the other spring.
6. Tighten the nuts (B) on both eyebolts down to expose about 3/4 inch (19 mm) of thread.
7. Add the other nuts (D). Hold the first nut (B) secure with a wrench and tighten the nuts (D) against the first nuts (B).
8. Position the fork of control rod (A, figure 4) over pivot stud (B). Be sure the handle on other end of control rod points down. Secure with spring clip (C).

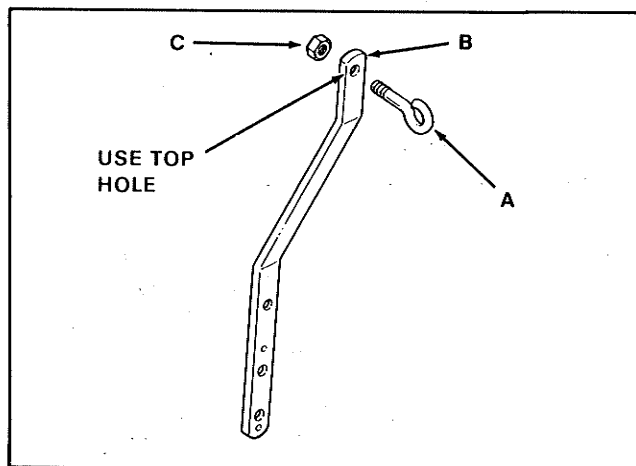

- A. Eyebolt
- B. Bracket
- C. Nut

Figure 5. Control Rod Bracket

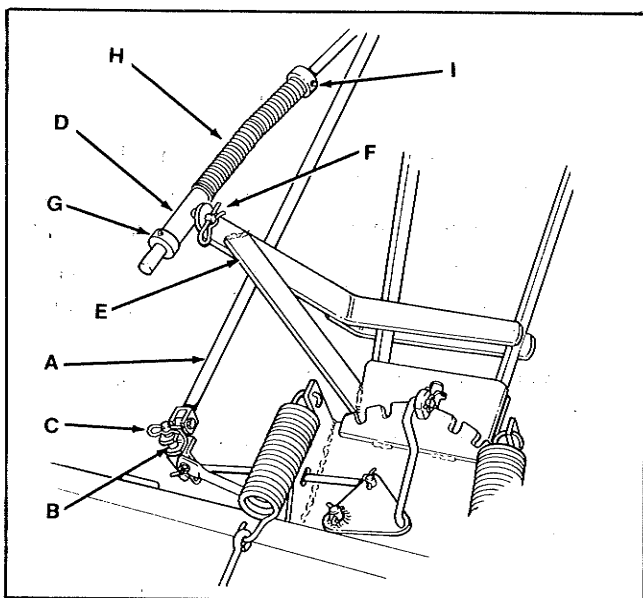

- A. Control Rod
- B. Pivot Stud
- C. Spring Clip
- D. Rod Guide
- E. Lift Bracket
- F. Spring Clip
- G. Lower Set Collar
- H. Spring
- I. Upper Set Collar

Figure 4. Attaching Control and Lift Arm

9. Install tip of rod guide (D) on lift rod into hole of lift bracket (E). Secure with spring clip (F).
10. Attach eyebolt (A, figure 5) to control rod bracket (B) and secure with nut (C).

INSTALLATION — BOTH MODELS

1. Swing the lift rod over and place it on top edge of blade. Drive the tractor over the push bar until rear of push bar is under front hitch.
2. Completely lower tractor lift arm (see Operation section if necessary).
3. Stop engine, remove key and set parking brake.
4. For the 42" blade, complete installation by performing the following steps.
 - a. Raise rear of push bar so its arms fit between lugs of hitch (L, figure 1) at rear of tractor axle. Use two pins (A) and spring clips (B) to secure push bar to hitch.
 - b. Insert hooked end of lift rod through hole in tractor lift arm (K). To do this, it may be necessary to loosen lower set collar (H). Secure lift rod with spring clip (J).
 - c. Perform adjustments in Adjustment section.

5. For the 46" Blade, complete installation by doing the following.

- a. Lift and position push bar to align with axle lugs (B, figure 6). Secure with two pins and spring clips (C).

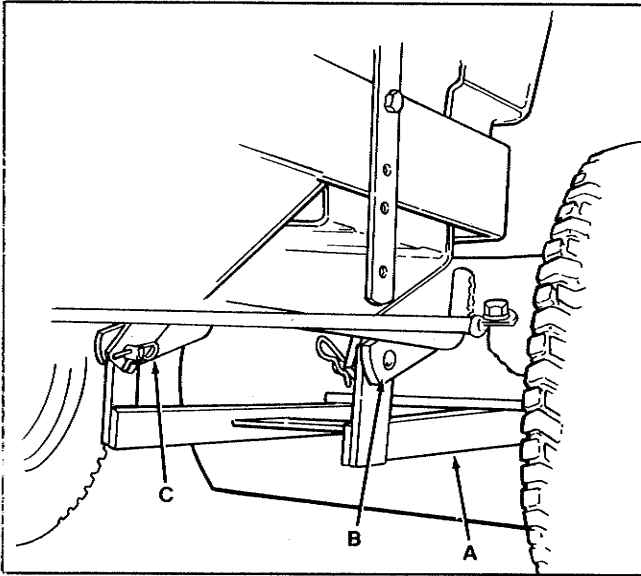

- A. Push Bar
- B. Axle Lugs
- C. Pins and Spring Clips

Figure 6. Installing Blade to Tractor

- b. Slide the eyebolt (E, figure 7) onto the control rod. Mount the control rod bracket (A, figure 7) to tractor frame with one capscrew and lockwasher.

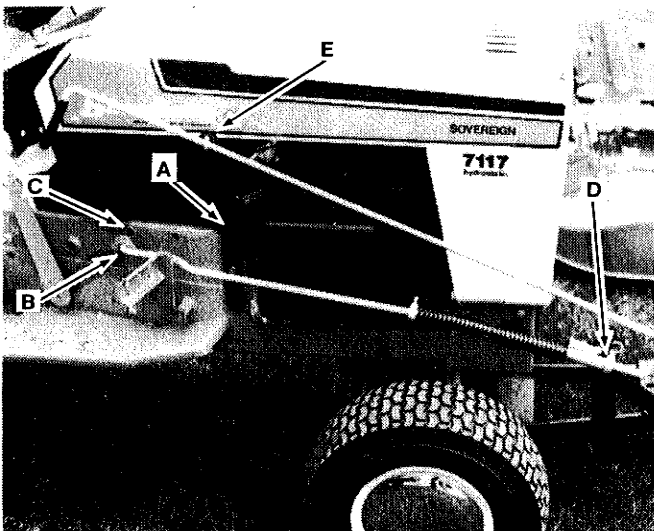

- A. Bracket
- B. Lift Arm
- C. Spring Clip
- D. Set Collar
- E. Eyebolt

Figure 7. Installing Lift Rod and Control Rod to Tractor

- c. Place bent end of lift rod in hole of tractor lift arm (B). Secure with spring clip (C). To attach lift rod it may be necessary to loosen set collar (D). Tighten collar after installing lift rod.

NOTE

When dual lift lever is used, install lift rod to lift arm so that spring clip (C) is installed outside of lift arm. This is opposite what is shown in figure 7.

- d. Carefully raise and lower blade several times using tractor lift and check for proper operation.

REMOVAL — 42 INCH BLADE

1. Using tractor lift lever or optional electric lift, lower blade completely to ground.
2. Stop engine, remove key, and set parking brake.
3. Remove spring clip (J, figure 1) and disconnect lift rod from lift arm (K). Store spring clip in hole of lift rod.
4. Remove both spring clips (B) and pins (A) and lower push bar (F) to ground. Store pins and spring clips in holes of push bar.

REMOVAL — 46 INCH BLADE

1. Using tractor lift lever or optional electric lift, lower blade to ground.
2. Stop engine, remove key, and set parking brake.
3. Remove spring clip (C, figure 4) and remove control rod from eyebolt (E, figure 7).
4. Pull out spring clip (C, figure 7) and remove lift rod. Lean rod against the blade.
5. Remove spring clips and pins (C, figure 6) and lower push bar assembly (A) to ground. Install pins and spring clips in push bar assembly for storage.
6. If desired, remove control rod bracket (A, figure 7) from tractor frame. Install capscrew and lockwasher on bracket for storage.

Operation & Normal Care

CONTROLS

See figure 8 to identify the controls.

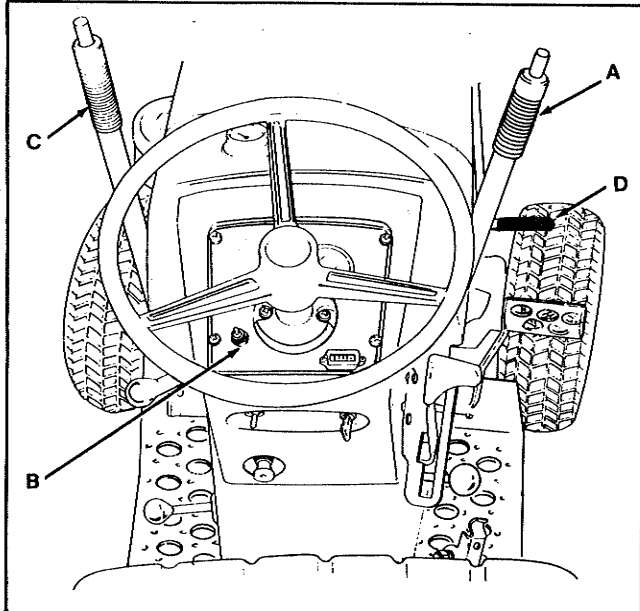

ITEM	NAME	FUNCTION
A	Dual Lift Lever (Optional)	Provides lift control for front mounted attachments such as the snow plow/dozer blade.
B	Power Lift Switch	Controls optional electrically operated power lift for snow plow/dozer blade if this item is present and item A and C are not present.
C	Lift Lever (Standard)	Used to raise and lower snow plow/dozer blade if items A and B are not present.
D	Control Rod Handle	Used to move blade to 1 to 5 angle positions (46" blade only). Twist the handle clockwise to release the latch. Move blade to desired position and allow handle to twist back to normal position so latch can fall back into nearest notch.

Figure 8. Location and Function of Controls

TRANSPORTING

For maximum ground clearance, transport the blade to and from work areas fully raised and angled straight ahead.



WARNING

Be particularly careful and operate at low tractor speeds in any area where the blade can hook on solid objects. Such objects can cause the tractor to be jarred or come to an abrupt stop.

DOZING & SNOW PLOWING

When dozing, push the dirt to the desired location, then drag the blade backwards for final leveling. Pack down the dirt or gravel by driving the tractor over the leveled area.

Use any grade to your advantage. Plow downhill and set the blade angle so that plowed material (especially snow) is moving downhill as it leaves the blade. For large drifts of snow, bite off small amounts instead of plowing a full blade width.

Set tractor speed to obtain the needed power to move the material. Operate at a safe speed, depending on conditions, so that you have complete control of the tractor. Rear wheel weights and chains are recommended for slippery surfaces.

OPERATION ON SLOPES

Never operate on slopes greater than 30 percent (16.7°) which is a rise of three feet (91 cm) in ten feet (305 cm) forward. Use two rear wheel weights (one per wheel) when operating on slopes greater than 20 percent (11.3°).

Always operate up and down the face of slopes, and never across the face. Use a slow ground speed on slopes.

NORMAL CARE

After dozing jobs, hose down the blade to remove excess dirt. Coat bare metal surfaces to prevent rusting. Lightly oil all pivot points.

If the wear plate on the bottom of the 42 inch blade is worn excessively, replace it with a new one by removing the six carriage bolts. The wear plate is shown in figure 1.

If the wear plate on the bottom of the 46 inch blade is worn excessively, remove the seven carriage bolts, turn it upside down, and re-install the seven carriage bolts.

Adjustments

SKID SHOES

For clearing snow from uneven or gravel surfaces, adjust the skid shoes so the blade rides above the ground. For grading, leveling or plowing smooth surfaces, adjust the skid shoes so the blade rides on the ground.

To adjust the skid, raise the blade off the ground and block with a piece of wood. For the 42 inch blade, remove the bolts (B, figure 9) lockwashers and nuts. For the 46 inch blade, loosen the bolts (B, figure 10). Move the skid shoes up or down to the desired height. For the 42 inch blade, reinstall the bolts (B, figure 9), lockwashers, and nuts. For the 46 inch blade, tighten the bolts (B, figure 10). Make sure the skid shoes are set to equal height.

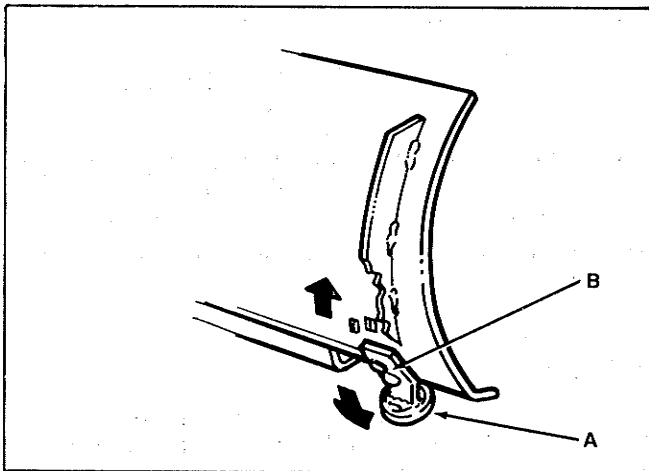

- A. Skid Shoes
- B. Carriage Bolts

Figure 9. Skid Shoe Adjustment

BLADE PRESSURE

To identify the parts mentioned in this procedure, refer to figure 1 for the 42 inch blade or figure 4 for the 46 inch blade.

The blade will float over minor bumps in the surface or dig into them depending upon the blade pressure adjustment. To adjust, park the tractor and blade on level ground and lower the blade completely. At this point, the gap between the rod guide and the lower set collar should be about 1 inch (25 mm). If not, loosen setscrew, move set collar and retighten setscrew.

If you want the blade to float, loosen setscrew and move upper set collar so the gap between it and spring is about 2 inches (51 mm).

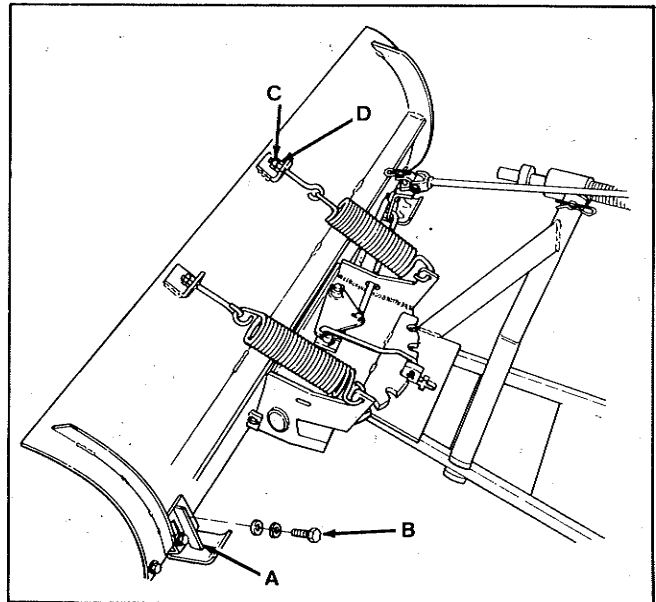

- A. Skid Shoes
- B. Bolts
- C. Front Nut
- D. Rear Nut

Figure 10. Skid Shoe Adjustment

If you want positive blade pressure that causes the blade to dig, loosen setscrew and move upper set collar so it compresses the spring 2 to 3 inches (51 to 76 mm). Be sure to retighten setscrew securely. The more the spring is compressed, the greater the blade pressure will be.

BLADE ANGLE

The angle of the 46 inch blade can be adjusted from the operator's position (see Operation section). To adjust the angle of the 42 inch blade, proceed as follows.

- a. Lift the blade off the ground using the lift lever or optional electric lift.
- b. Remove the pivot pin (C, figure 1), move the blade to desired angle and reinstall the pivot pin in a different hole.

SPRING TENSION — 46 INCH BLADE ONLY

This snow plow/dozer blade is spring loaded so that when the blade strikes a solid object, the springs will allow the blade to release rather than cause damage. To adjust spring tension, hold rear nut (D, figure 10) and loosen front nut (C). Adjust rear nut (D). Tighten nut to increase spring tension or loosen to decrease. Tighten front nut (C) so the two nuts are drawn firmly together.



